

The logo consists of the letters 'KLH' in a bold, white, sans-serif font, positioned centrally within a solid red square.

KLH[®]

MADE FOR BUILDING
BUILT FOR LIVING

LIFTING SYSTEMS
WITH EC DECLARATION OF CONFORMITY



Version: Lifting Systems with EC Declaration of Conformity, 04/2024

Publisher and responsible for content: © KLH Massivholz GmbH

The content of this brochure is the intellectual property of the company and is protected by copyright. The statements are recommendations and suggestions only; liability on the part of the publisher is excluded. Any type of reproduction is strictly forbidden and only permitted after written approval from the publisher.

KLH® and the KLH® logo are internationally registered trademark rights of KLH Massivholz GmbH. The fact that a mark is not included in the list and/or not indicated as registered trademark (brand) in a text cannot be interpreted in anyway that this mark is not a registered trademark (brand) and/or that this mark could be used without prior written acceptance of KLH Massivholz GmbH.

CONTENT

01 EXAMPLES OF LIFTING SYSTEMS WITH AN EC DECLARATION OF CONFORMITY	03
02 POSSIBLE LIFTING SCENARIOS	04
03 LOAD TABLE TURNING UPRIGHT OR STANDING LIFTING	06
04 LOAD TABLE FLAT LIFTING	08
05 LOAD TABLE INCLINED LIFTING	10
06 EXAMPLES OF LIFTING EQUIPMENT INSTALLED ON SITE	12
06.1 Lifting clamp Power Clamp III, Type: D40/90	12
06.2 Load attachment Sihga® Pick	13
06.3 Würth ASSY® transport anchor system	14
06.4 RAMPA® lifting system type X	15
06.5 WASP hook for timber elements transport	16
06.6 RAPTOR rigging device for timber elements	17
07 FACTORY-INSTALLED LIFTING EQUIPMENT	18
07.1 KLH® lifting gear system “W” (“Wall System”)	18
07.2 KLH® lifting gear system “FD” (“Floor Diagonal System”)	19
07.3 KLH® lifting gear system “FB VLS” (“Visible Lifting System”)	20
07.4 KLH® lifting gear system “VLS S” (“Visible Lifting System for Slab Elements”)	21
07.5 KLH® lifting gear system “FB” (“Floor Bolt System”)	22
07.6 KLH® lifting gear system “VLS W” (“Visible Lifting System for Wall Elements”)	23
08 UNLOADING, TEMPORARY STORAGE, LIFTING	24
09 ELEMENT INSTALLATION	25
10 KLH EC CERTIFICATES OF CONFORMITY	26

LIFTING SYSTEMS

This brochure is intended to provide an overview of lifting systems that have become established for the installation of KLH® - CLT. The basis for use is either the EC Declarations of Conformity obtained by KLH for lifting equipment installed in the factory or the operating instructions of the respective manufacturers for lifting equipment installed on site (please always use the latest documents from the respective websites and inform us of any deviations from this brochure, for example due to updates). Please observe the country-specific safety regulations for all systems and ensure that the prescribed personal protective equipment and construction site equipment are used.

The type and position of the lifting equipment is determined and ordered by the customer. It must be coordinated with both the construction site processes and the means of transportation of the delivery, especially if it is necessary to turn upright or flip elements at the place of arrival. Required drill holes must be marked in the element plans and, if necessary, sealed or filled in a suitable manner on site after installation.







For elements with a visible surface, holes for lifting equipment on the visible surface must always be avoided. If panels are turned upright or turned over on site, additional lifting equipment must be provided for the different load cases where necessary.

For the assembly of small elements (weight < 250 kg), we recommend the on-site use of lifting screws (e.g. Würth ASSY® transport anchor system or WASP hook for timber elements transport) instead of lifting equipment with loops.

For deliveries with widely varying element weights, different lifting equipment for light and heavy elements is usually advantageous. Our team will be happy to advise you on the choice of suitable lifting equipment.

01 EXAMPLES OF LIFTING SYSTEMS WITH AN EC DECLARATION OF CONFORMITY

LIFTING EQUIPMENT INSTALLED ON SITE

Lifting clamp Power Clamp III, Type: D40/90 (www.pitzl-connectors.com)	
Load attachment Sihga® Pick (www.sihga.com)	
Würth ASSY® transport anchor system (www.wuerth.de)	
RAMPA® lifting system type X (www.rampa.com)	
WASP hook for timber elements transport (www.rothoblaas.de)	
RAPTOR rigging device for timber elements (www.rothoblaas.de)	

FACTORY-INSTALLED LIFTING EQUIPMENT

KLH® lifting gear system “W” (“Wall System”)	
KLH® lifting gear system “FD” (“Floor Diagonal System”)	
KLH® lifting gear system “FB VLS” (“Visible Lifting System”)	
KLH® lifting gear system “VLS S” (“Visible Lifting System for Slab Elements”)	
KLH® lifting gear system “FB” (“Floor Bolt System”)	
KLH® lifting gear system “VLS W” (“Visible Lifting System for Wall Elements”)	

02 POSSIBLE LIFTING SCENARIOS

"TURNING UPRIGHT"

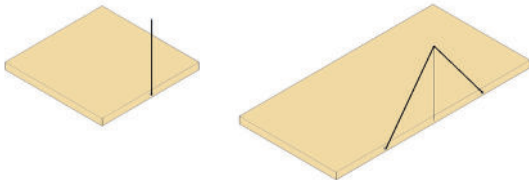

Turning upright, laying down or flipping elements

The load-bearing capacity of the lifting equipment must be designed for half the weight of the element;

additional lifting equipment may be required for this load case only.

"STANDING LIFTING"

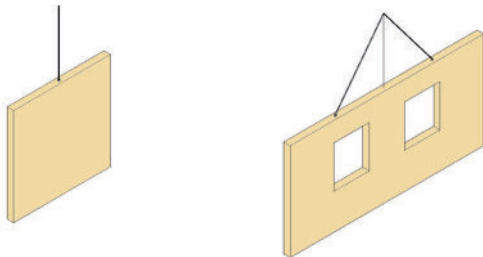

Lifting upright elements

1 or 2 lifting points (max. distance 6 m);

symmetrical arrangement to the element's centre of gravity;

small elements (weight < 250 kg) should be installed with lifting screws.

"FLAT LIFTING"

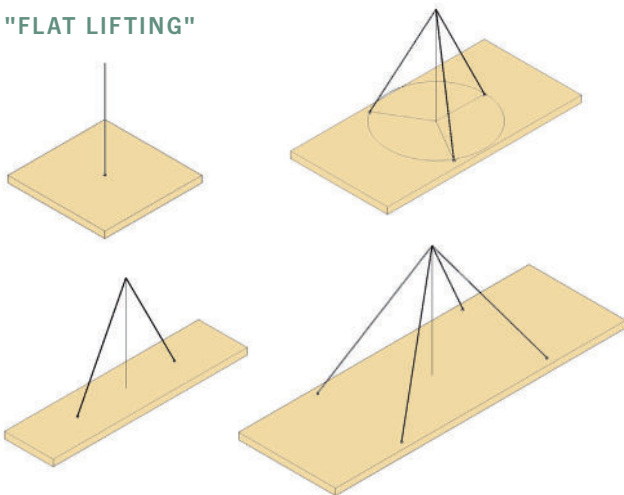

Lifting horizontal elements

1 to max. 4 lifting points (max. distance 6 m);

the element weight must be distributed evenly to all lifting points in relation to the centre of gravity;

for elements with 4 lifting points, the maximum element weight also depends on the type of hanger;

small elements (weight < 250 kg) should be installed with lifting screws.

"INCLINED LIFTING"

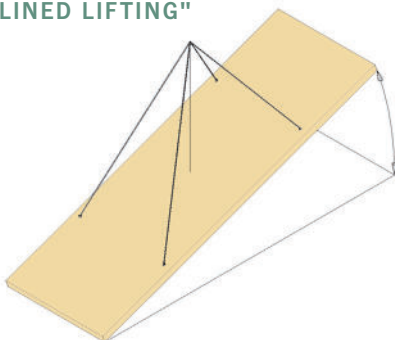

Lifting inclined elements

Max. 4 lifting points (max. distance 6 m) analogous to lifting horizontal elements;

small elements (weight < 250 kg) should be installed with lifting screws.

02 POSSIBLE LIFTING SCENARIOS

GENERAL PRINCIPLES

In addition to the element weight, dynamic loads must be taken into account during lifting operations. Depending on the type of lifting device and the hanger as well as the ambient conditions on the construction site, this influence is taken into account by the dynamic coefficient (vibration coefficient φ).

When specifying the load capacity of lifting equipment, the position of the lifting gear (on side surfaces or narrow sides), the position of the element (vertical, horizontal, inclined), the type of hanger and the angle between the hanger and the axis of the lifting gear are taken into account. When turning upright or flipping elements and then lifting them, check whether the selected lifting equipment is suitable for both lifting scenarios.

The position of the lifting gear always refers to the centre of gravity of the element, with the aim of distributing the total load evenly across the lifting gear. Selecting 2 or 4 lifting points per element results in a symmetrical arrangement around the centre of gravity.

If the element weight is to be evenly distributed over 3 lifting points, then these must be at the same distance from the centre of gravity and have an angle of 120° to each other – this can possibly be implemented for small or square elements. In practice, however, in most cases this arrangement is not possible.

For elements with 4 lifting points, the full load capacity of the lifting equipment may only be allowed when using a statically determinate hanger (with compensating seesaw or crossbeam); when using a statically indeterminate hanger or with asymmetrical load distribution, the load capacity of the lifting equipment must be reduced in accordance with the applicable operating instructions.

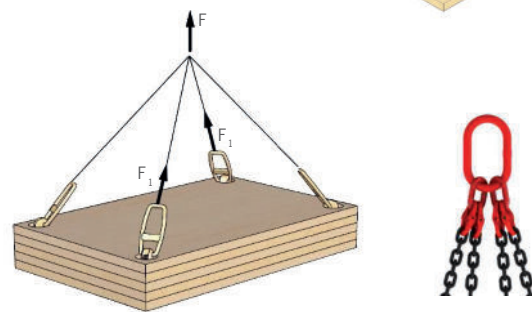
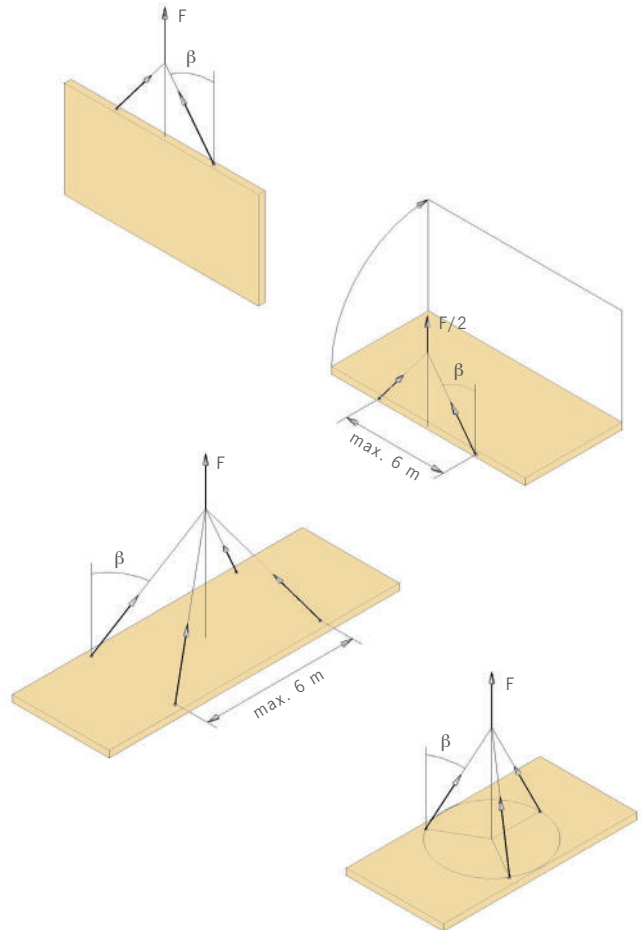

statically indeterminate hanger
www.wuerth.de | www.pewag.at

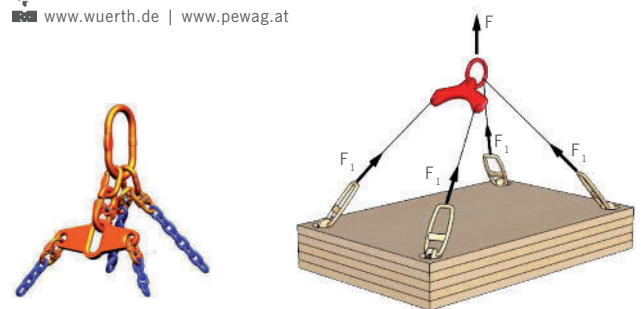



statically determinate hanger with compensating seesaw
www.pewag.at | www.wuerth.de

03 LOAD TABLE TURNING UPRIGHT OR STANDING LIFTING

LIFTING UPRIGHT ELEMENTS

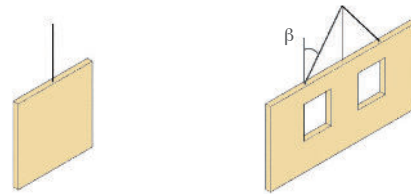
Use the lifting equipment in accordance with the valid operating instructions.

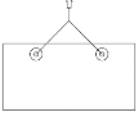

Lifting gear Type	Installation	Panel thickness [mm]	Max. element weight with 1 lifting device [kg]	Max. element weight with 2 lifting devices [kg]	Angle of the hanger to the vertical, remarks
Power Clamp III D40/90	on site on the narrow side	≥ 80 ≥ 100 ≥ 160	1000 1200 1500	1300 1500 2000	for $\beta = 7^\circ - 60^\circ$ for all panel thicknesses with asymmetrical load distribution, the load capacity is reduced by 50%, vibration coefficient $\varphi = 1.3$
Sihga® Pick	on site on the narrow side	≥ 90	see operating instructions, lifting angle $\beta \geq 5^\circ$ to the borehole axis	1607 1160	for $\beta = 30^\circ$ for $\beta = 45^\circ$ vibration coefficient $\varphi = 1.3$
	on site on the narrow side	≥ 70		1154 	vibration coefficient $\varphi = 1.3$
Würth ASSY® transport anchor system	on site ASSY 4 COMBI T 12x160/145 on the narrow side	≥ 120	see operating instructions, possible with longer lifting screws	1188 970 screws inclined to the vertical at the angle β	for $\beta = 30^\circ$ for $\beta = 45^\circ$ load case "axial tension", vibration coefficient $\varphi = 1.3$
WASP® hook for timber elements transport	on site VGS Ø11 x 150 on the narrow side	≥ 70	is not recommended	874 714 screws inclined to the vertical at the angle β 342 206 screws perpendicular to the surface	for $\beta = 30^\circ$ for $\beta = 45^\circ$ load case "inclined", vibration coefficient $\varphi = 1.2$ for $\beta = 30^\circ$ for $\beta = 45^\circ$ load case "perpendicular", vibration coefficient $\varphi = 1.2$

03 LOAD TABLE TURNING UPRIGHT OR STANDING LIFTING

TURNING ELEMENTS UPRIGHT

Use the lifting equipment in accordance with the valid operating instructions.

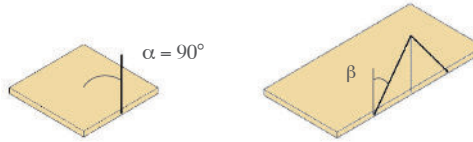

Lifting gear Type	Installation	Panel thickness [mm]	Max. element weight with 1 lifting device [kg]	Max. element weight with 2 lifting devices [kg]	Angle of the hanger to the vertical, remarks
Power Clamp III D40/90	on site on the narrow side	≥ 80	250	600	for $\beta = 7^\circ - 60^\circ$ for all panel thicknesses with asymmetrical load distribution, the load capacity is reduced by 50%, vibration coefficient $\varphi = 1.3$
		≥ 90	380	1000	
		≥ 100	380	1200	
		≥ 120	380	1400	
		≥ 160	600	1800	
Sihga® Pick	on site on the narrow side	≥ 90	see operating instructions, lifting angle $\beta \geq 5^\circ$ to the borehole axis	1040	vibration coefficient $\varphi = 1.3$
		≥ 120		1667	
		≥ 160		1900	

TURNING ELEMENTS UPRIGHT OR LIFTING UPRIGHT ELEMENTS

Hanger angle $\beta = 30^\circ - 45^\circ$;
the specified maximum element weights apply to both load cases.

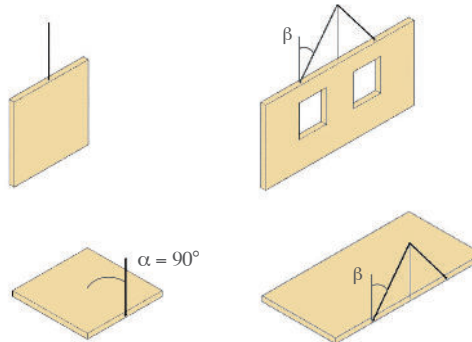

KLH® lifting gear system Type	Installation	Panel thickness [mm]	Max. element weight with 1 lifting device [kg]	Max. element weight with 2 lifting devices [kg]
W 1000	at the factory	≥ 60	1000	2000
W 2500	at the factory	≥ 125	2500	5000
VLS W2 / VLS W2 D	on request	≥ 75 - 90	500 / 1000	1000 / 2000
VLS W3 / VLS W3 D	on request	≥ 95 - 120	800 / 1600	1600 / 3200
VLS W4 / VLS W4 D	on request	≥ 125 - 185	800 / 1600	1600 / 3200
VLS W5 / VLS W5 D	on request	≥ 190	800 / 1600	1600 / 3200

The use of lifting equipment installed on site is recommended for small elements.

04 LOAD TABLE FLAT LIFTING

LIFTING HORIZONTAL ELEMENTS

Use the lifting equipment
in accordance with the valid operating instructions.

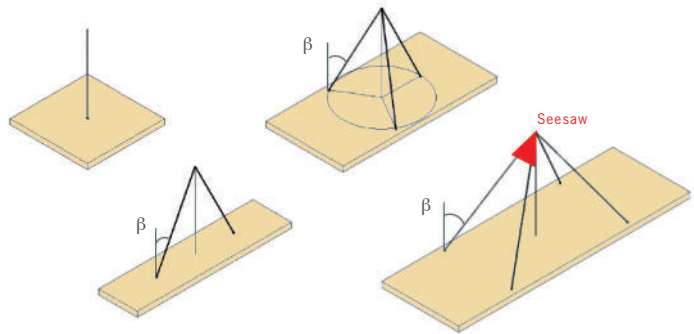

Lifting gear Type	Installation	Panel thickness [mm]	Max. element weight with 1 lifting device [kg]	Max. element weight with 2 lifting devices [kg]	Max. element weight with 3 lifting devices [kg]*	Max. element weight with 4 lifting devices [kg]	Angle of the hanger to the vertical, remarks
Power Clamp III D40/90	on site	≥ 60	1500 for $\beta = 0^\circ$	2100 1500	3150 2250	3150 2250 without seesaw 4200 3000 with seesaw**	for $\beta = 7^\circ - 45^\circ$ for $\beta = 45^\circ - 60^\circ$ for $\beta = 7^\circ - 45^\circ$ for $\beta = 45^\circ - 60^\circ$ with asymmetrical load distribution, the load capacity is reduced by 50%, vibration coefficient $\varphi = 1.3$
Sihga® Pick	on site	≥ 70	see operating instructions, lifting angle $\beta \geq 5^\circ$ to the borehole axis	1853 1620	2780 2430	3707 3240 only with seesaw**	for $\beta = 30^\circ$ for $\beta = 45^\circ$ vibration coefficient $\varphi = 1.3$
Würth ASSY® transport anchor system	on site ASSY 4 COMBI T 12x120/100 perpendicular to the surface	≥ 120	not permitted	726 538	1089 807	1452 1076 with seesaw**	for $\beta = 30^\circ$ for $\beta = 45^\circ$ load case "inclined pull", vibration coefficient $\varphi = 1.3$
	on site ASSY 4 COMBI T 12x160/145 perpendicular to the surface	≥ 160	not permitted	950 664	1425 996	1900 1328 with seesaw**	for $\beta = 30^\circ$ for $\beta = 45^\circ$ load case "inclined pull", vibration coefficient $\varphi = 1.3$
WASP® hook for timber elements transport	on site VGS Ø11 x 100 perpendicular to the surface	≥ 110	is not recommended	570 382	855 573	1140 764 with seesaw**	for $\beta = 30^\circ$ for $\beta = 45^\circ$ load case "perpendicular", vibration coefficient $\varphi = 1.2$
	on site VGS Ø11 x 150 perpendicular to the surface	≥ 160	is not recommended	952 636	1428 954	1904 1272 with seesaw**	for $\beta = 30^\circ$ for $\beta = 45^\circ$ load case "perpendicular", vibration coefficient $\varphi = 1.2$

*) even load distribution must be ensured

***) statically determinate hanger

04 LOAD TABLE FLAT LIFTING

LIFTING HORIZONTAL ELEMENTS

Hanger angle $\beta = 30^\circ - 45^\circ$;
statically indeterminate hanger.

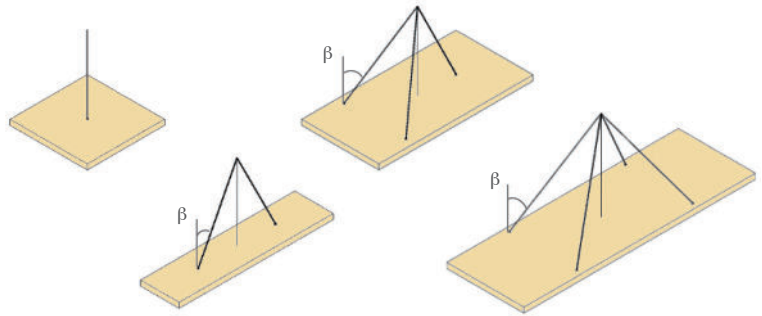

KLH® lifting gear system Type	Installation	Panel thickness [mm]	Max. element weight with 1 lifting device [kg]	Max. element weight with 2 lifting devices [kg]	Max. element weight with 3 lifting devices [kg]	Max. element weight with 4 lifting devices [kg]
FD 1000	at the factory	≥ 60	1000	2000	2000	3000
FD 2500	at the factory	≥ 125	2500	5000	5000	7500
FB10 VLS S1	at the factory	$\geq 80 - 95$ ≥ 100	600 800	1200 1600	1200 1600	1800 2400
FB10 VLS S2	at the factory	≥ 120	900	1800	1800	2700
FB25 VLS S3	at the factory	≥ 140	1400	2800	2800	4200
FB25 VLS S4	at the factory	≥ 180	2500	5000	5000	7500
VLS S1	at the factory*	$\geq 80 - 95$ ≥ 100	600 800	1200 1600	1200 1600	1800 2400
VLS S2	at the factory*	≥ 120	900	1800	1800	2700
VLS S3	at the factory	≥ 140	1400	2800	2800	4200
VLS S4	at the factory	≥ 180	2500	5000	5000	7500
FB 1000	on request	≥ 60	1000	2000	2000	3000
FB 2500	on request	≥ 125	2500	5000	5000	7500

*) with 3-layer KLH® - CLT, the bolt axis must run transverse to the fibre direction of the top layer

The use of lifting equipment installed on site is recommended for small elements.

05 LOAD TABLE INCLINED LIFTING

LIFTING INCLINED ELEMENTS

Use the lifting equipment in accordance with the valid operating instructions.

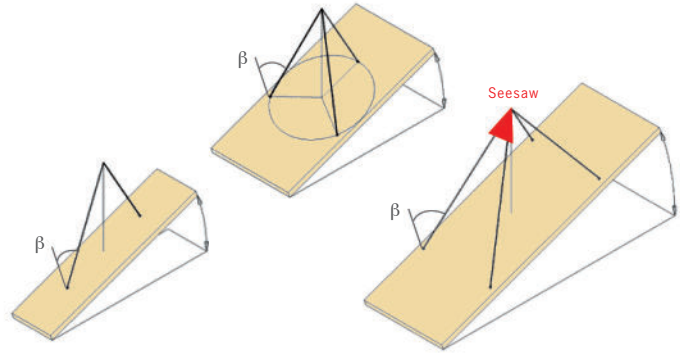

Lifting gear Type	Installation	Panel thickness [mm]	Max. element weight with 2 lifting devices [kg]	Max. element weight with 3 lifting devices [kg]*	Max. element weight with 4 lifting devices [kg]	Angle of the hanger to the drill hole axis / screw axis, remarks
Power Clamp III D40/90	on site	≥ 60	1050	1050	1600 <small>without seesaw</small>	for β = 45° - 60°
					2100 <small>with seesaw**</small>	for β = 45° - 60° with asymmetrical load distribution, the load capacity is reduced by 50%, vibration coefficient φ = 1.3
Sihga® Pick	on site	≥ 70	1620	2430	3240 <small>only with seesaw**</small>	for β = 45° for β > 45° installation with crossbeam, vibration coefficient φ = 1.3
Würth ASSY® transport anchor system	on site ASSY 4 COMBI T 12x120/100 perpendicular to the surface	≥ 120	538 350	807 525	1076 700 <small>with seesaw**</small>	for β = 45° for β = 60° load case "inclined pull", element inclination max. 15°, vibration coefficient φ = 1.3
	on site ASSY 4 COMBI T 12x160/145 perpendicular to the surface	≥ 160	664 418	996 627	1328 836 <small>with seesaw**</small>	for β = 45° for β = 60° load case "inclined pull", element inclination max. 15°, vibration coefficient φ = 1.3

*) even load distribution must be ensured

***) statically determinate hanger

Note: even with the same load distribution, the lifting points are subject to different loads, as the hangers are not the same length; the maximum element weight is determined by the lower, decisive lifting point (with the largest occurring angle β). The specified load values assume a uniform load on the lifting points.

05 LOAD TABLE INCLINED LIFTING

LIFTING INCLINED ELEMENTS

Hanger angle $\beta = 30^\circ - 45^\circ$;
statically indeterminate hanger.

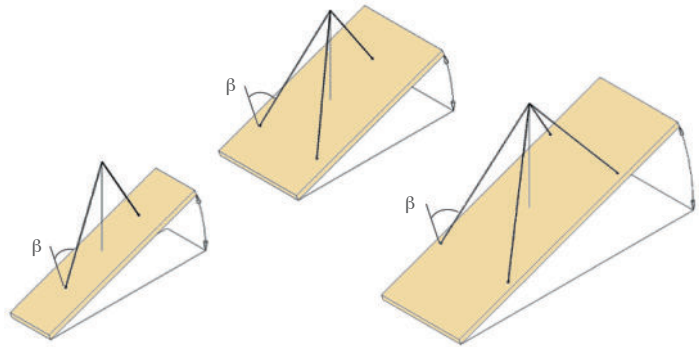

KLH® lifting gear system Type	Installation	Panel thickness [mm]	Max. element weight with 2 lifting devices [kg]	Max. element weight with 3 lifting devices [kg]	Max. element weight with 4 lifting devices [kg]
FD 1000	at the factory	≥ 60	2000	2000	3000
FD 2500	at the factory	≥ 125	5000	5000	7500
FB10 VLS S1	at the factory	$\geq 80 - 95$ ≥ 100	840 1120	840 1120	1260 1680
FB10 VLS S2	at the factory	≥ 120	840	840	1890
FB25 VLS S3	at the factory	≥ 140	1120	1120	2940
FB25 VLS S4	at the factory	≥ 180	3500	5000	5250
VLS S1	at the factory*	$\geq 80 - 95$ ≥ 100	840 1120	1200 1600	1260 1680
VLS S2	at the factory*	≥ 120	1260	1800	1890
VLS S3	at the factory	≥ 140	1960	2800	2940
VLS S4	at the factory	≥ 180	3500	5000	5250
FB 1000	on request	≥ 60	2000	2000	3000
FB 2500	on request	≥ 125	5000	5000	7500

*) with 3-layer KLH® - CLT, the bolt axis must run transverse to the fibre direction of the top layer

The use of lifting equipment installed on site is recommended for small elements.

06 EXAMPLES OF LIFTING EQUIPMENT INSTALLED ON SITE

06.1 LIFTING CLAMP POWER CLAMP III, TYPE: D40/90

Scope of KLH services:

- Drill holes on side surfaces
- Drill holes on narrow sides along master panel edges and of at least 100 mm thickness

This lifting system must be used in accordance with the valid operating instructions for "Power Clamp 40-90-III":

<https://www.pitzl-connectors.com/en/products/product-list/55890.1000>

Extract from the operating instructions (as of January 2024):

Maximum load capacity per Power Clamp: 1500 kg; drill hole: diameter 40 mm (max. 41 mm), minimum depth 93 mm (or 73 mm when using the blue spacer in accordance with the valid operating instructions for "Spacer for Power Clamp III D40/90 to reduce the drilling depth").



www.pitzl-connectors.com



www.pitzl-connectors.com

Minimum edge distances:

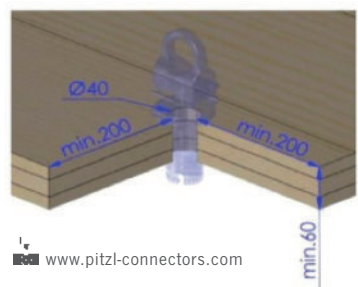
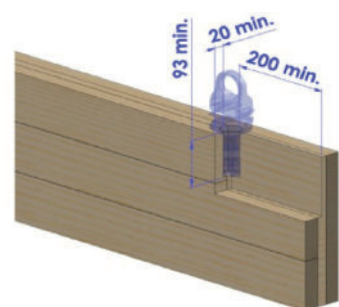

www.pitzl-connectors.com

Drill holes on narrow sides:

Panel thickness min. 80 mm; edge distance (residual wood thickness) min. 20 mm (or 200 mm).

Drill holes on side surfaces:

Panel thickness min. 100 mm, or 80 mm when using the spacer, or 60 mm for drilled-through, visible holes; edge distances (residual wood width) min. 200 mm.

For other types of lifting clamp (e.g. Power Clamp III, type D25/70), the respective manufacturer's operating instructions apply.

Practical tip: the operator must check the condition and quality of the drill hole immediately before lifting and re-drill on site if necessary – have suitable drill bits ready!

06 EXAMPLES OF LIFTING EQUIPMENT INSTALLED ON SITE

06.2 LOAD ATTACHMENT SIHGA® PICK

Scope of KLH services:

- Drill holes on side surfaces
- Drill holes on narrow sides along master panel edges and of at least 100 mm thickness

This lifting system must be used in accordance with the valid operating instructions for "Sihga® Pick":

<https://www.sihga.com/en/pick/>

Extract from the operating instructions (as of January 2024):

Lifting may only be carried out at an angle of $\geq 5^\circ$ to the borehole axis.

Drill hole:

Diameter 50 mm (max. 51 mm), minimum depth 70 mm, axis of the hole always 90° to the surface.

Drill holes on narrow sides:

Panel thickness min. 90 mm; edge distance (residual wood thickness) min. 20 mm (or 250 mm edge-centre distance); end grain max. 40 mm (= max. lamella thickness).

Drill holes on side surfaces:

Panel thickness min. 90 mm, or 70 mm for drilled-through, visible holes; edge-centre distances min. 250 mm.



 www.sihga.com

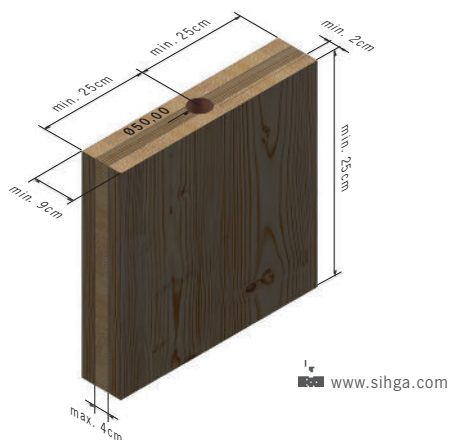

For other types of the load attachment (e.g. Sihga® Pick Max), the respective manufacturer's operating instructions apply.

Practical tip: the operator must check the condition and quality of the drill hole immediately before lifting and re-drill on site if necessary – have suitable drill bits ready!

06 EXAMPLES OF LIFTING EQUIPMENT INSTALLED ON SITE

06.3 WÜRTH ASSY® TRANSPORT ANCHOR SYSTEM

Scope of KLH services:

- Delivery of Würth ASSY® 4 COMBI T transportation anchor screw 12x120/100 or 12x160/145
- Delivery of Würth ASSY® transport anchor 1.3 tonnes

This lifting system must be used in accordance with the valid operating instructions for the "Würth ASSY® Transport Anchor System":

https://www.wuerth.de/web/de/assy/zulassungen_1/zulassungen_1.php

Extract from the operating instructions (as of January 2024):

Würth spherical head anchors of load group 1 – 1.3 tonnes may be used in combination with the following screws:

- Würth ASSY® 4 COMBI T transportation anchor screw \varnothing 10 and 12 mm
- Würth ASSY® 4 COMBI timber screw \varnothing 12 mm
- Würth ASSY® PLUS VG 4 COMBI construction screw \varnothing 12 mm



 www.wuerth.de

The following screw load cases are possible:

Axial tension

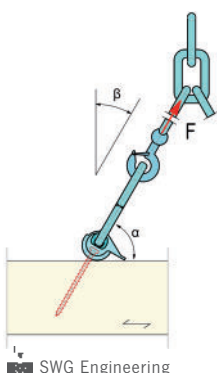

Inclined pull

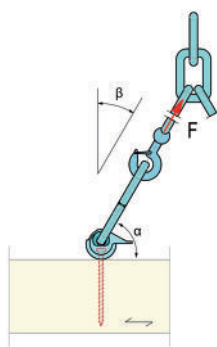

Inclined pull with precise blind-hole milling

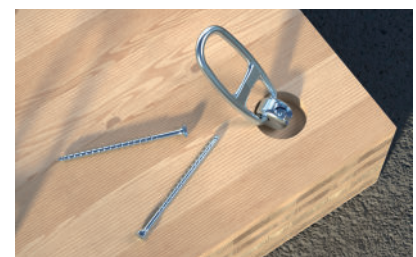
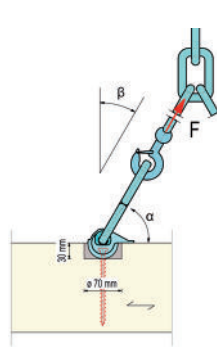

 www.wuerth.de

If necessary, the customer must produce precisely fitting blind-hole millings or install transverse tension reinforcements when using the lifting screws on narrow sides.

For safety reasons, the lifting screws may only be used once.

06 EXAMPLES OF LIFTING EQUIPMENT INSTALLED ON SITE

06.4 RAMPA® LIFTING SYSTEM TYPE X

Scope of KLH services (on request):

- Drill holes on side surfaces
- Drill holes on narrow sides along master panel edges and of at least 100 mm thickness
- Installation of the RAMPA® inserts in the KLH® elements

This lifting equipment must be used in accordance with the valid operating instructions for "Audited 1-click RAMPA® lifting system":

<https://www.rampa.com/eu/en/Products/RAMPA-Lifting-gear/>

Extract from the product data sheet (as of January 2024):

RAMPA® lifting system type X consisting of: load suspension type X and insert type X:

- Insert type X D25x50: drill hole diameter 23 mm, minimum panel thickness 60 mm
- Insert type X D33x73: drill hole diameter 31 mm, minimum panel thickness 80 mm
- Insert type X D36x73: drill hole diameter 34 mm, minimum panel thickness 120 mm



 www.rampa.com

Inserts must be screwed in at right angles to the surface and flush with the surface. They may be installed on the sides and narrow sides of elements. The following load cases can be modelled:

- Lifting upright elements
- Lifting horizontal elements
- Turning a horizontal element upright and then lifting it

For other types of RAMPA® lifting equipment (e.g. RAMPA® inserts type SKL), the respective manufacturer's operating instructions apply.

06 EXAMPLES OF LIFTING EQUIPMENT INSTALLED ON SITE

06.5 WASP HOOK FOR TIMBER ELEMENTS TRANSPORT

This lifting equipment must be used in accordance with the valid operating instructions:

<https://www.rothoblaas.com/products/machines-and-tools/transport-and-lifting/wasp>

Extract from the technical documentation
(as of January 2024):

WASP is made of very high strength carbon steel, WASPL is forged from high-strength steel. Both versions are coated with white electro-galvanising.



Suitable screws:		
	VGS [mm]	HBS [mm]
WASP	Ø11	Ø10
WASPL	Ø11 Ø13	Ø12

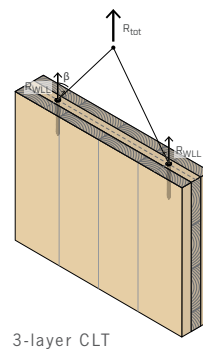
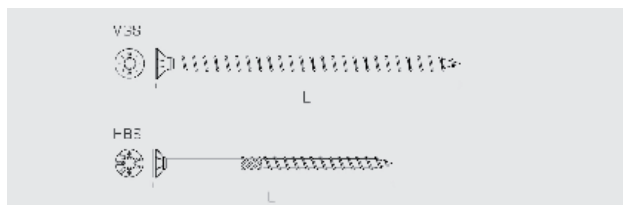

3-layer CLT

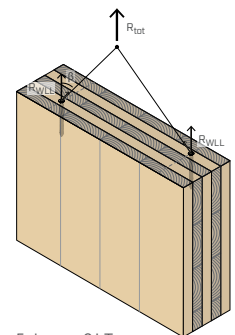

5-layer CLT

Possible installation of lifting screws:

- perpendicular
- perpendicular with milling
- inclined

On narrow sides, lifting screws may only be screwed into the inner layers and only at right angles to the fibres.

The angle β between the screw axis and the hanger must not exceed 60°.

For safety reasons, lifting screws may only be used once and must be fully countersunk into the wooden element or unscrewed after use.

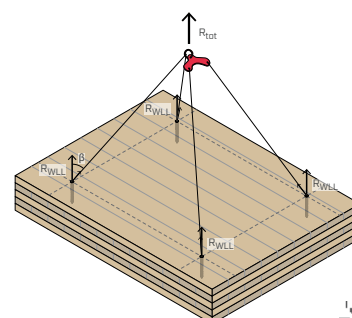

06 EXAMPLES OF LIFTING EQUIPMENT INSTALLED ON SITE

06.6 RAPTOR RIGGING DEVICE FOR TIMBER ELEMENTS

This lifting equipment must be used in accordance with the valid operating instructions:

<https://www.rothoblaas.com/products/machines-and-tools/transport-and-lifting/raptor>

Extract from the technical documentation
(as of January 2024):

The metal plate with 6 holes and the lifting hook are made of steel. It provides 3 installation options with HBS PLATE screws (HBSP Ø 10) of different lengths depending on the load conditions (axial or transverse loads) and the material being transported (L = 80 to 180 mm).

- 6 screws: maximum load capacity
- 4 or 2 screws for lifting lighter elements

Possible layout of screws

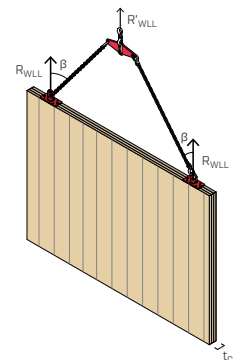
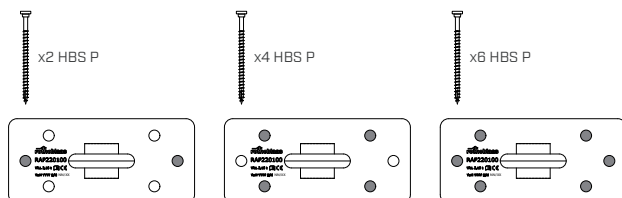

The angle β between the screw axis and the hanger must not exceed 60° .

For safety reasons, lifting screws may only be used once.

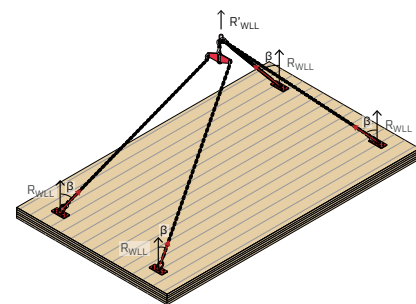

From a panel thickness of 100 mm, the RAPTOR rigging device may be attached to narrow sides and used for turning upright ("tipping" phase).

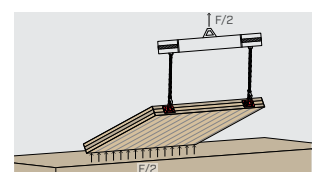
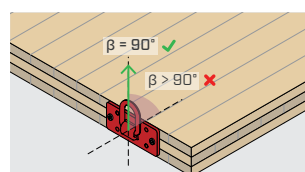

07 FACTORY-INSTALLED LIFTING EQUIPMENT

07.1 KLH® LIFTING GEAR SYSTEM “W” (“WALL SYSTEM”)

Type: “W 1000” and “W 2500”

Scope of KLH services:

- Drill hole (1 piece with diameter 30 mm)
- Installation of the one-way lifting loop (type Pewag 1000 or Pewag 2500)

EC Declaration of Conformity: see annex page 26

Description and characteristics:

- Visibly installed lifting device primarily for wall elements in non-visible quality
- 1 or max. 2 loops per element (max. distance 6 m)

The following load cases can be modelled:

- Lifting upright elements
- Turning a horizontal element upright and then lifting it



Minimum edge distances:

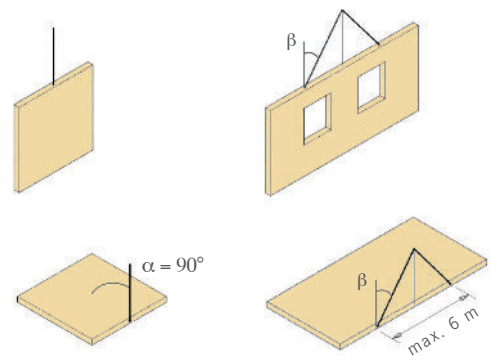
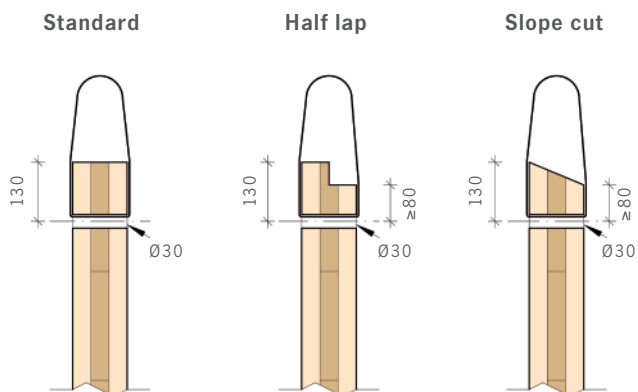

Depending on the load, the loops can leave marks in the wood. If necessary, the holes can be re-drilled (widened) on site with a 35 mm drill bit and sealed with a wooden plug.

07 FACTORY-INSTALLED LIFTING EQUIPMENT

07.2 KLH® LIFTING GEAR SYSTEM “FD” (“FLOOR DIAGONAL SYSTEM”)

Type: “FD 1000” and “FD 2500”

Scope of KLH services:

- Drill holes (2 pieces with a diameter of 30 mm, distance $e = 100$ mm at 45° to the fibre direction)
- Installation of the one-way lifting loop (type Pewag 1000 or Pewag 2500)

EC Declaration of Conformity: see annex page 26

Description and characteristics:

- Visibly installed lifting device primarily for slab and roof elements in non-visible quality
- 1 or max. 4 loops per element (max. distance 6 m)

The following load cases can be modelled:

- Lifting horizontal elements
- Assembling horizontal or inclined elements

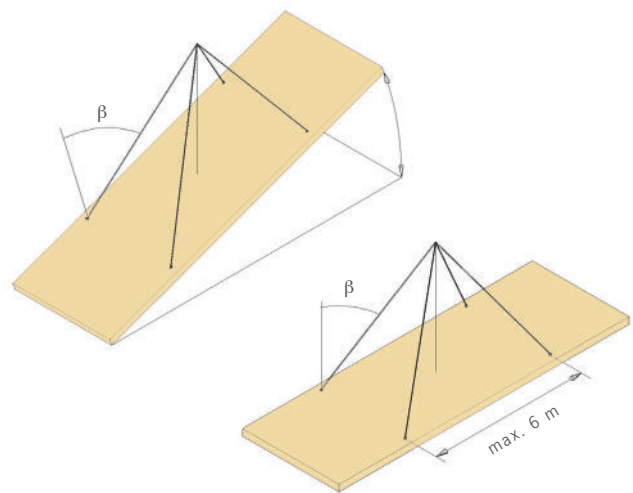

Installation of the lifting loops:



1. Insert the lifting loop into the hole



2. Feed the loop back through the second hole



3. Lifting situation with built-in FD system

Depending on the load, the loops can leave marks in the wood. If necessary, the holes can be re-drilled (widened) on site with a 35 mm drill bit and sealed with a wooden plug.

07 FACTORY-INSTALLED LIFTING EQUIPMENT

07.3 KLH® LIFTING GEAR SYSTEM “FB VLS”

Type: “FB10 VLS S1”, “FB10 VLS S2”, “FB25 VLS S3” and “FB25 VLS S4”

Description:

- KLH decides whether the "FB" or "VLS S" lifting gear is to be installed
- The "VLS S" lifting gear is shown graphically in the element plans
- However, the elements are supplied with the "FB" or "VLS S" lifting gear

The lifting devices "FB" and "VLS S" are described in the following chapters, whereby the designation "FB10" corresponds to the lifting device "FB 1000" and the designation "FB25" corresponds to the lifting device "FB 2500". By taking into account the different (site-specific) installation options at KLH, a cost advantage can be passed on to the customer when using this lifting system.

Ordered lifting gear:	Graphical representation in element drawing as:	Factory-installed lifting gear:
“FB10 VLS S1”	VLS S1	“FB 1000” or “VLS S1”
“FB10 VLS S2”	VLS S2	“FB 1000” or “VLS S2”
“FB25 VLS S3”	VLS S3	“FB 2500” or “VLS S3”
“FB25 VLS S4”	VLS S4	“FB 2500” or “VLS S4”



Variant 1: “FB VLS” delivered as “FB”



Variant 2: “FB VLS” delivered as “VLS S”

Characteristics:

- Visible or concealed lifting device primarily for slab and roof elements in visible quality
- 1 to max. 4 loops per element (max. distance 6 m)

The following load cases can be modelled:

- Lifting horizontal elements
- Assembling horizontal or inclined elements

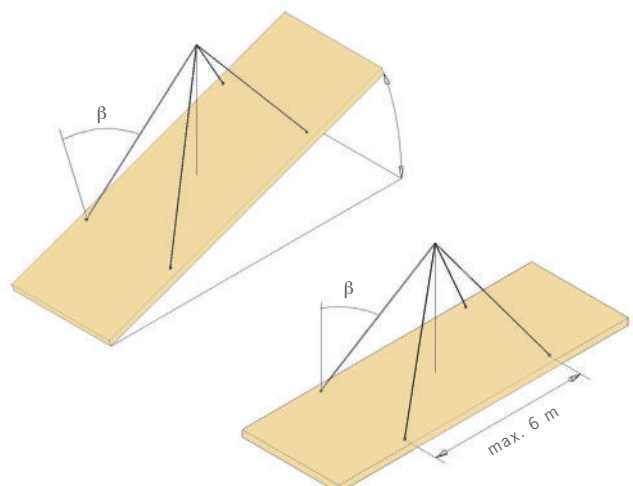

07 FACTORY-INSTALLED LIFTING EQUIPMENT

07.4 KLH® LIFTING GEAR SYSTEM “VLS S” (“VISIBLE LIFTING SYSTEM FOR SLAB ELEMENTS”)

Type: “VLS S1”, “VLS S2”, “VLS S3” and “VLS S4”

Scope of KLH services:

- Blind hole (1 piece with diameter 68 mm)
- Installation of the one-way lifting loop (type Pewag 600 or Pewag 1000 or Pewag 2500) with rod dowel and stowing the loop in the blind hole

EC Declaration of Conformity: see annex page 27

Illustration of the edge distances for VLS S systems
(the area marked in red must not be processed)

Description and characteristics:

- Concealed lifting device primarily for slab and roof elements in visible quality
- 1 to max. 4 loops per element (max. distance 6 m)

The following load cases can be modelled:

- Lifting horizontal elements
- Assembling horizontal or inclined elements (max. 45°)

Minimum edge distances:

Examples of permissible edge processing

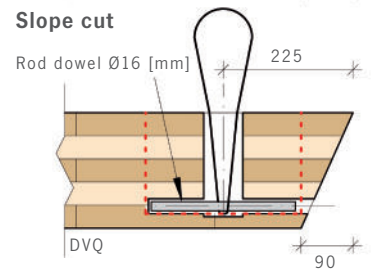
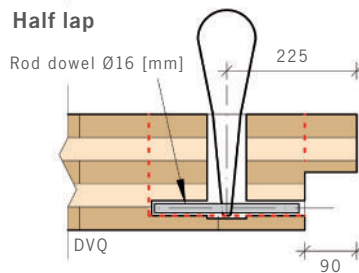
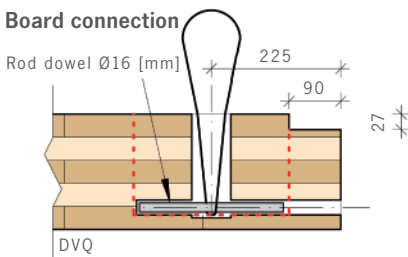
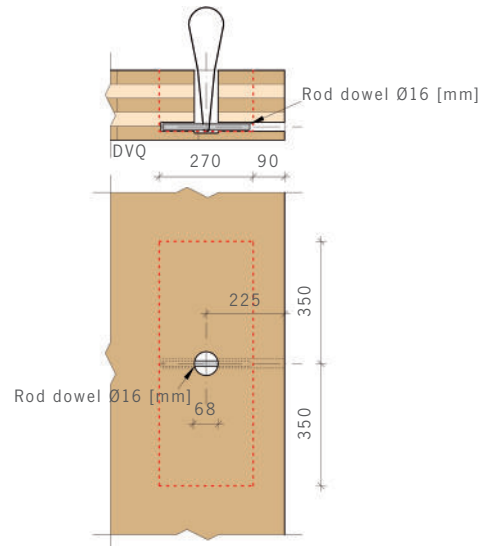

The galvanised rod dowel remains in the KLH element. If necessary, the blind hole must be filled on site in a suitable manner.

Installation of the lifting gear:



1. Insert the loop and dowel into the hole

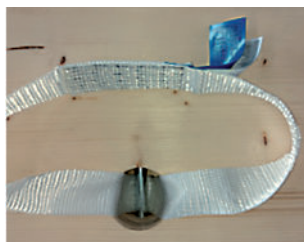

2. Lifting situation with built-in system VLS S



3. Transport situation with rolled-up loop in the blind hole

07 FACTORY-INSTALLED LIFTING EQUIPMENT

07.5 KLH® LIFTING GEAR SYSTEM “FB” (“FLOOR BOLT SYSTEM”)

Type: “FB 1000” and “FB 2500”

Scope of KLH services (on request):

- Drill hole (1 piece with diameter 30 mm)
- Installation of the one-way lifting loop (type Pewag 1000 or Pewag 2500) with safety bolt (reusable)

EC Declaration of Conformity: see annex page 26

Description and characteristics:

- Visibly installed lifting gear primarily for slab and roof elements in visible quality
- 1 to max. 4 loops per element (max. distance 6 m)

The following load cases can be modelled:

- Lifting horizontal elements
- Assembling horizontal or inclined elements

Installation of the lifting loops:



1. Insert the loop into the hole



2. Do not position the loop seam in the area of the bolt or lifting hook

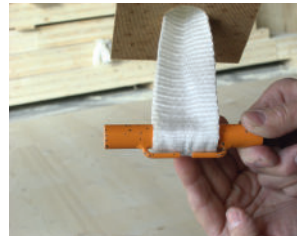

3. Insert the bolt with the safety clip facing downwards and position it accordingly



4. Lifting situation with built-in FB system

Minimum edge distances:

Standard

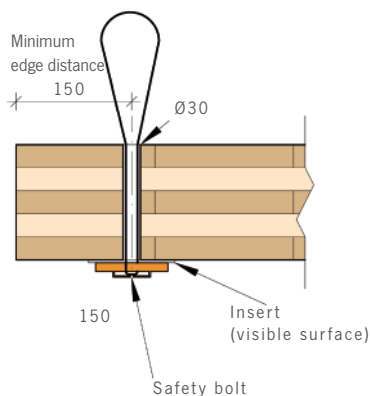

Half lap

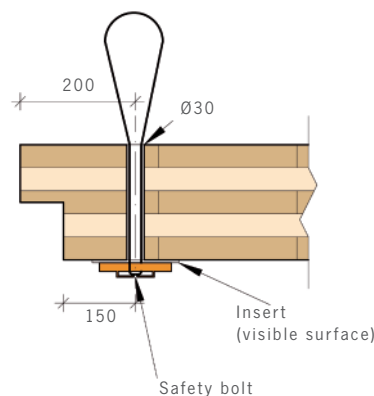

Slope cut

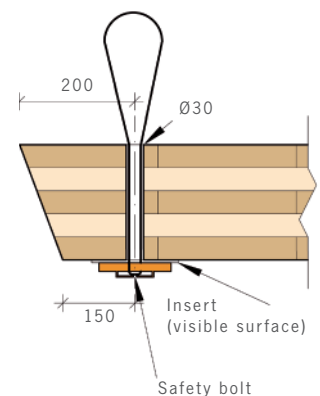

Depending on the load, the loops can leave marks in the wood. If necessary, the holes can be re-drilled (widened) on site with a 35 mm drill bit and sealed with a wooden plug.

07 FACTORY-INSTALLED LIFTING EQUIPMENT

07.6 KLH® LIFTING GEAR SYSTEM “VLS W” (“VISIBLE LIFTING SYSTEM FOR WALL ELEMENTS”)

Type: “VLS W2”, “VLS W3”, “VLS W4” and “VLS W5”
 “VLS W2 D”, “VLS W3 D”, “VLS W4 D” and “VLS W5 D”

Scope of KLH services (on request):

- Drill hole for rod dowel and loop (1 each with a diameter of 25 mm)
- Installation of the one-way lifting loop (type Pewag 1000 or Pewag 2500) with rod dowel

EC Declaration of Conformity: see annex page 28

Description and characteristics:

- Concealed lifting device primarily for wall elements in visible quality
- 1 to max. 2 loops per element (max. distance 6 m)

The following load cases can be modelled:

- Lifting upright elements
- Turning a horizontal element upright and then lifting it



If the lifting gear is installed in pairs, the lifting hook must be hooked into both loops

Minimum edge distances:

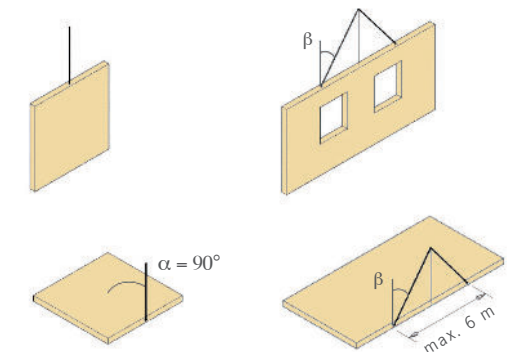
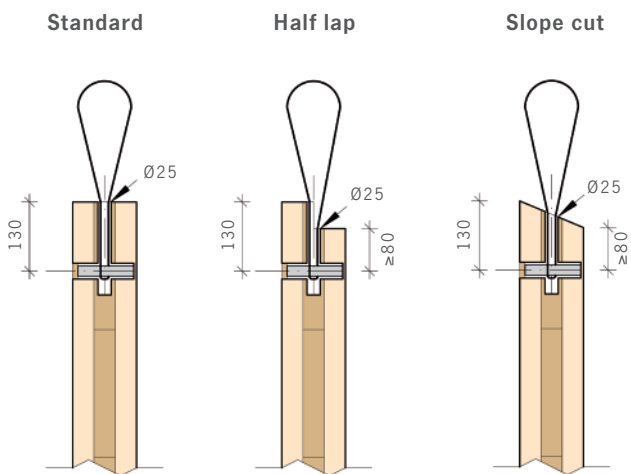

The galvanised rod dowel remains in the KLH element.

08 UNLOADING, TEMPORARY STORAGE, LIFTING

GUIDELINE FOR THE USE OF KLH® LIFTING GEAR SYSTEMS WITH EC CERTIFICATE OF CONFORMITY

Lifting operations using KLH® lifting gear systems with an EC certificate of conformity may only be carried out with suitable lifting equipment and a suitable hanger.

Please observe the following procedure for lifting, unloading, interim storing, and assembling:

- Visually inspect the installed one-way lifting loops
- Hook into all installed lifting loops (hook opening to the outside)
- Maximum distance between the lifting points 6 m
- Inclination angle of the hanger $\beta = 30^\circ - 45^\circ$

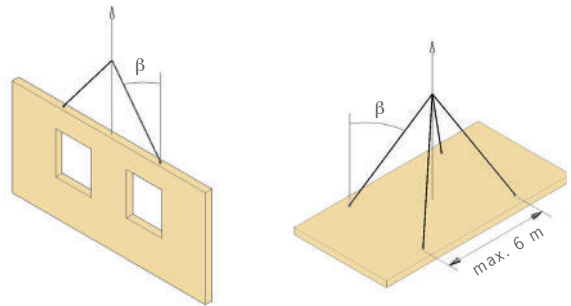

TRANSPORT FLAT → LIFT FLAT

OR

TRANSPORT STANDING → LIFT STANDING

Unloading and assembling are carried out directly from the trailer using the built-in KLH® lifting gear; the position of the element remains unchanged.

TRANSPORT FLAT → TURNING UPRIGHT → LIFT STANDING

The built-in KLH® lifting devices of type "W" and "VLS W" are suitable both for turning upright and for lifting the element upright. When turning upright, the elements must be prevented from slipping (direction of pull $\alpha = 110^\circ$). This variant can be used for horizontal delivery of wall elements.

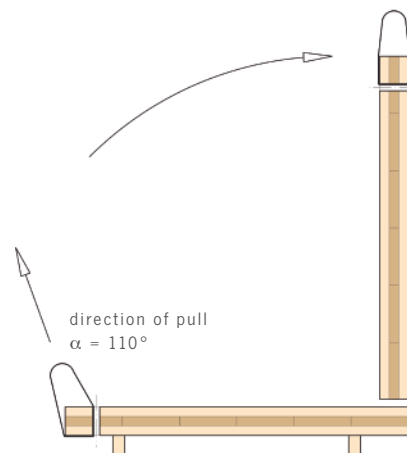

Load securing in accordance with legal regulations and provisions

TRANSPORT STANDING → LAYING DOWN → LIFT FLAT

The element is unloaded and deposited horizontally and securely using the built-in KLH® lifting gear type "W" or "VLS W". The hanger must then be transferred to the lifting gear for horizontal lifting (e.g. type "VLS S"). In exceptional cases, the loops supplied must be installed on site in the factory-prepared holes in accordance with the installation instructions. This variant can be used for upright delivery of slab or roof elements.

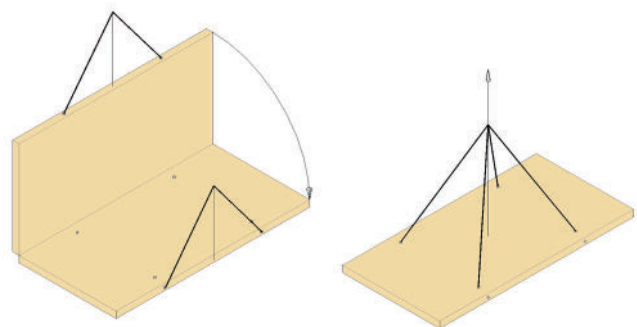

1. Unloading with the unloading lifting system

2. Assembling with the assembly lifting system

Load securing in accordance with legal regulations and provisions

09 ELEMENT INSTALLATION

VERTICAL ELEMENT INSTALLATION FOR WALL ELEMENTS

FIX WALL ELEMENT

- Bring the wall into the installation position – ensure that the wall is secured in position

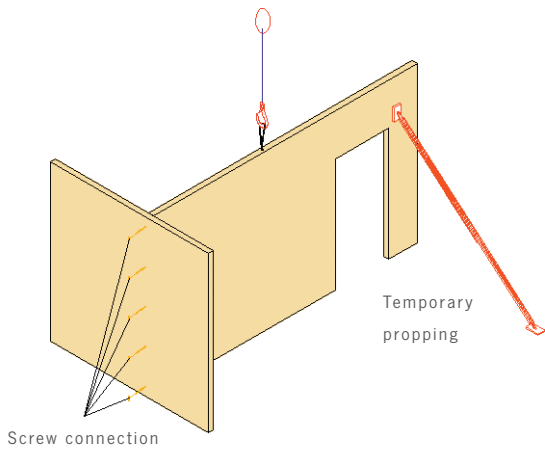

UNHOOK CRANE HOOKS

- Observe the applicable employee protection regulations and other provisions

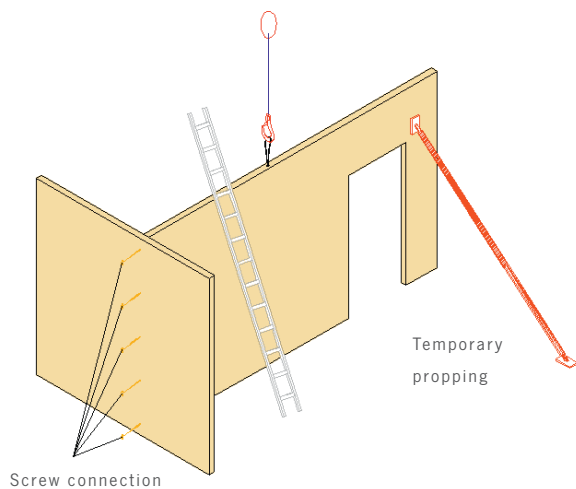

DISPOSE OF ONE-WAY LIFTING LOOPS

HORIZONTAL ELEMENT INSTALLATION FOR SLAB AND ROOF ELEMENTS

FIX SLAB/ROOF ELEMENT

- Bring the slab/roof element into the installation position – ensure that the element is secured in position

UNHOOK CRANE HOOKS

- When accessing the slab or roof elements, observe the applicable employee protection regulations and other provisions



CUT THE LIFTING LOOPS WHEN USING THE VLS SYSTEM

- Wearing safety gloves and using a safety knife in accordance with the Employee Protection Ordinance



DECLARATION of CONFORMITY

accord. Directive of Machinery 2006/42/EG

The Signee: *Dipl.-Ing. Dr. techn. Erich Moschik*
Zvilingenieur für Maschinenbau, A-9300 St. Veit/Glan

declares, that the system / machinery

- 1. Product:** *KLH Lifting Systems
for lifting wall and ceiling elements
consisting of lifting loops, manuf. Pewag as well as bolts*
- 2. Type:** *W 1000, W 2500, FD 1000, FD 2500, FB 1000, FB 2500*
- 3. Year of Manufacture:** *2009 / Adaptation 2021 / Adaptation 2023*
- 4. User:** *KLH Massivholz GmbH, A-8842 Teufenbach-Katsch, Gewerbstraße 4
KLH Massivholz Wiesenau GmbH, A-9400 Wolfsberg, Schwemmtratten 7*

meets the following essential safety requirements and standards:

- Bestimmungen der EG-Richtlinien:

2006/42/EG *Directive of Machinery*

- harmonisierte Normen

- EN 12100 -1* *Safety of machinery - General principles for design — Risk assessment and risk reduction*
- EN 547-3* *Safety of machinery - Human body measurements*
- EN 614-2* *Safety of machinery - Ergonomic design principles,
Part 2: Interactions between the design of machinery and work tasks*
- EN 818-2* *Short link chain for lifting purposes - Safety
Part 2: Medium tolerance chain for chain slings - Grade 8*
- EN 1492-1* *Textile slings - Safety
Part 1: Flat woven webbing slings made of man-made fibers for general purpose use*
- EN 13854* *Standards on Safety of Machinery - Minimum gaps to avoid crushing of parts of the
human body*
- EN ISO 13857* *Safety of machinery - Safety distances to prevent hazard zones being reached by upper
and lower limbs*
- EN ISO 14120* *Safety of machinery - General requirements for the design and construction of fixed and
movable guards*
- EN ISO 14123* *Safety of machinery - Reduction of risks to health from hazardous substances emitted by
machinery*

Originally issued 16.06.2012
Prolongation 01.06.2021
Prolongation 04.12.2023
Valid until 03.12.2028

St. Veit/Glan, 04.12.2023



Dipl.-Ing. Dr. techn. Erich Moschik
 St. Veit / Glan

The content of this declaration is in conformance with the DIN EN ISO/IEC 17050-1

10 KLH EC CERTIFICATES OF CONFORMITY

DECLARATION of CONFORMITY

accord. Directive of Machinery 2006/42/EG

The Signee: *Dipl.-Ing. Dr. techn. Erich Moschik*
Zvilingenieur für Maschinenbau, A-9300 St. Veit/Glan

declares, that the system / machinery

- 1. Product:** *VLS-S Visible Lifting System*
For lifting ceiling elements
- 2. Type:** *S1, S2, S3, S4 – ceiling elements*
- 3. Year of Manufacture:** *2021 / Adaptation 2023*
- 4. User:** *KLH Massivholz GmbH, A-8842 Teufenbach-Katsch, Gewerbestraße 4*
KLH Massivholz Wiesenau GmbH, A-9400 Wolfsberg, Schwemmtratten 7

meets the following essential safety requirements and standards:

- Bestimmungen der EG-Richtlinien:

2006/42/EG *Directive of Machinery*

- harmonisierte Normen

- EN 12100 -1 *Safety of machinery - General principles for design — Risk assessment and risk reduction*
- EN 547-3 *Safety of machinery - Human body measurements*
- EN 614-2 *Safety of machinery - Ergonomic design principles,*
Part 2: Interactions between the design of machinery and work tasks
- EN 818-2 *Short link chain for lifting purposes - Safety*
Part 2: Medium tolerance chain for chain slings - Grade 8
- EN 1492-1 *Textile slings - Safety*
Part 1: Flat woven webbing slings made of man-made fibers for general purpose use
- EN 13854 *Standards on Safety of Machinery - Minimum gaps to avoid crushing of parts of the human body*
- EN ISO 13857 *Safety of machinery - Safety distances to prevent hazard zones being reached by upper and lower limbs*
- EN ISO 14120 *Safety of machinery - General requirements for the design and construction of fixed and movable guards*
- EN ISO 14123 *Safety of machinery - Reduction of risks to health from hazardous substances emitted by machinery*

Originally issued *16.06.2021*

Prolongation: *04.12.2023*

Valid until *03.12.2028*

St. Veit/Glan, 04.12.2023



Dipl.-Ing. Dr. techn. Erich Moschik
St. Veit / Glan

The content of this declaration is in conformance with the DIN EN ISO/IEC 17050-1

10 KLH EC CERTIFICATES OF CONFORMITY

EG - KONFORMITÄTS - ERKLÄRUNG

accord. Directive of Machinery 2006/42/EG

The Signee: *Dipl.-Ing. Dr. techn. Erich Moschik
Zvilingenieur für Maschinenbau, A-9300 St. Veit/Glan*

declares, that the system / machinery

- 1. Product:** *VLS-Visible Lifting System
For lifting wall and ceiling elements
consisting of lifting loops, TGH rod and one-way bolts*
- 2. Type:** *W2, W3, W4, W5 – wall elements
D1, D2, D3 – ceiling elements*
- 3. Year of Manufacture:** *2009 / Adaptation 2021 / Adaptation 2023*
- 4. User:** *KLH Massivholz GmbH, A-8842 Teufenbach-Katsch, Gewerbestraße 4
KLH Massivholz Wiesenau GmbH, A-9400 Wolfsberg, Schwemmratten 7*

meets the following essential safety requirements and standards:

- Bestimmungen der EG-Richtlinien:

2006/42/EG Directive of Machinery

- harmonisierte Normen

EN 12100 -1 Safety of machinery - General principles for design — Risk assessment and risk reduction

EN 547-3 Safety of machinery - Human body measurements

EN 614-2 Safety of machinery - Ergonomic design principles,
Part 2: Interactions between the design of machinery and work tasks

EN 818-2 Short link chain for lifting purposes - Safety
Part 2: Medium tolerance chain for chain slings - Grade 8

EN 1492-1 Textile slings - Safety
Part 1: Flat woven webbing slings made of man-made fibers for general purpose use

EN 13854 Standards on Safety of Machinery - Minimum gaps to avoid crushing of parts of the human body

EN ISO 13857 Safety of machinery - Safety distances to prevent hazard zones being reached by upper and lower limbs

EN ISO 14120 Safety of machinery - General requirements for the design and construction of fixed and movable guards

EN ISO 14123 Safety of machinery - Reduction of risks to health from hazardous substances emitted by machinery

Originally issued 16.06.2012
First Prolongation 01.06.2021
Second Prolongation 04.12.2023
Valid until 03.12.2028

St. Veit/Glan, 04.12.2023



Dipl.-Ing. Dr. techn. Erich Moschik
St. Veit / Glan

The content of this declaration is in conformance with the DIN EN ISO/IEC 17050-1



KLH MASSIVHOLZ GMBH

Gewerbestraße 4 | 8842 Teufenbach-Katsch | Austria

Tel +43 (0)3588 8835 | Fax +43 (0)3588 8835 415

office@klh.at | www.klh.at



Aus Liebe zur Natur



Gedruckt auf umweltfreundlichem Papier